

Chil-LED™

The Coolest Light for Cold Places

Temperature Controlled Area Light



Efficiency

- **Designed and optimised exclusively for use in insulated envelope chilled and frozen environments**
- **Huge energy savings – over 75% when compared with Metal Halide**
- **Low energy – High performance light output**
- **Wide choice of beam angles available to optimise use of available light**
- **Almost zero heat gain in the cold area, reducing refrigeration costs**
- **Save energy, save money**

Olivewood Chil-LED™ is the only lighting system that is exclusively designed for use in refrigerated environments. Chil-LED™ is unique in that the compact, lightweight LED light source is the only part of the system that is actually inside the cold area. All of the other components – the electronic control systems, heat sink, mounting brackets – are situated outside the cold room, in the ambient environment. Chil-LED™ is the leading energy saving cold store lighting product on the market.



OLIVEWOOD

Efficiency through Technology



Efficiency



Design



Installation



Reliability

T: +44 (0) 1749 840 439
E: info@olivewoodtech.co.uk

[@olivewoodtech](https://twitter.com/olivewoodtech)

<http://olivewoodtech.co.uk>

Burnt Wood Depot, Roomead Road, Binegar, Somerset, BA3 4UL

Design

- **Low profile and small size reduces intrusion and ceiling clutter**
- **Smooth, simple form, easy to clean and prevents dirt build-up**
- **Polycarbonate construction for light weight and durability**
- **Save energy, save money**

Chil-LED™ overcomes the traditional conflict between good lighting and efficient refrigeration in cold rooms. Lights are sources of heat and, in cold rooms, heat gain from lighting is a costly problem. Maintaining a refrigerated environment is an energy-intensive operation. The air conditioning equipment uses power as it works to remove heat. LEDs (Light Emitting Diodes) are exceptionally efficient light sources. However 70% of the energy that they consume is lost as waste heat. In ordinary lights, this unwanted heat by-product is radiated into the cold room. **Olivewood Chil-LED™** uses an advanced heat transit system, known as a heat pipe, to extract the heat from the light at source. It is then redirected and transported through the insulated envelope ceiling, and dissipated outside the cold store.

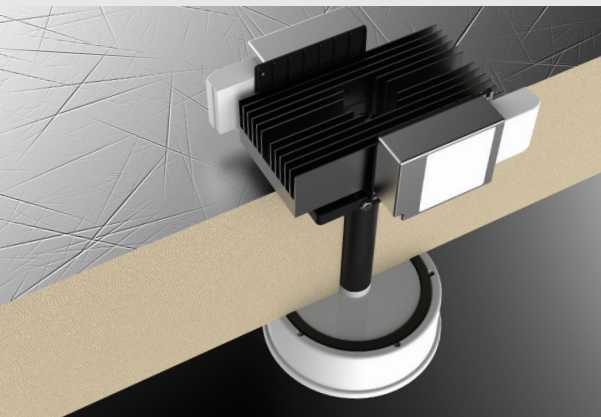

Size Comparison - to Scale

Chil-LED™ is far superior in it's design and application. **Olivewood** has made Chil-LED™ the first choice when it comes to replacing increasingly obsolete lighting systems within cold places.



Chil-LED™



Traditional Low Bay

Design Features

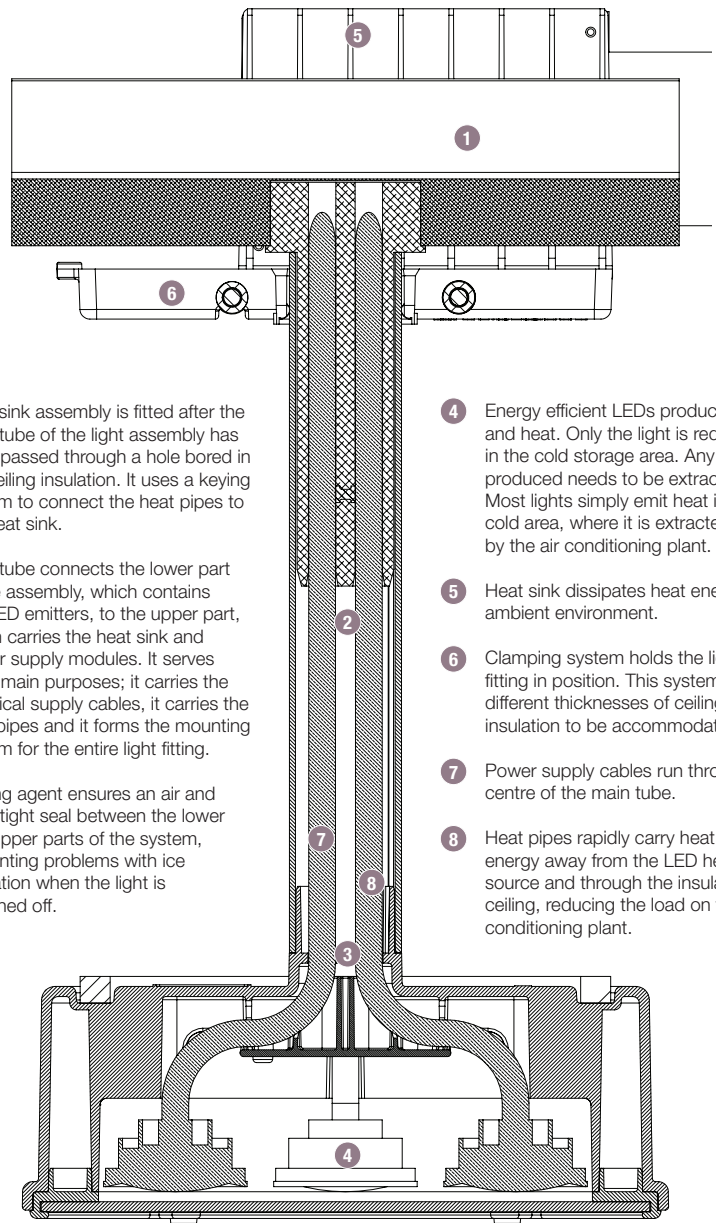

- 1 Heat sink assembly is fitted after the main tube of the light assembly has been passed through a hole bored in the ceiling insulation. It uses a keying system to connect the heat pipes to the heat sink.
- 2 Main tube connects the lower part of the assembly, which contains the LED emitters, to the upper part, which carries the heat sink and power supply modules. It serves three main purposes; it carries the electrical supply cables, it carries the heat pipes and it forms the mounting system for the entire light fitting.
- 3 Potting agent ensures an air and watertight seal between the lower and upper parts of the system, preventing problems with ice formation when the light is switched off.
- 4 Energy efficient LEDs produce light and heat. Only the light is required in the cold storage area. Any heat produced needs to be extracted. Most lights simply emit heat into the cold area, where it is extracted later by the air conditioning plant.
- 5 Heat sink dissipates heat energy into ambient environment.
- 6 Clamping system holds the light fitting in position. This system allows different thicknesses of ceiling insulation to be accommodated.
- 7 Power supply cables run through the centre of the main tube.
- 8 Heat pipes rapidly carry heat energy away from the LED heat source and through the insulated ceiling, reducing the load on the air conditioning plant.

Installation

- Simple, fast installation
- Single penetration through insulation for wiring, mounting bracket and heat evacuation
- All connections and controls are outside the insulated envelope, for easy access and improved reliability
- Save energy, save money

Cold room designers insist on maintaining the integrity of the insulated walls and ceiling panels of the cold room. Every hole through a panel needs to be completely sealed to prevent warm, moist air from entering the temperature controlled area, creating problems with condensation and icing. Most lights have multiple mounting points and a separate cable entry point - all of which require holes in the insulation to be drilled, filled and sealed. The unique **Olivewood Chil-LED™** design combines the mounting bracket, cable entry and heat extraction system in one unit, which requires only a single mounting hole. This design reduces installation costs and ensures the integrity of the insulated panel.



Temperature and Heat Dissipation

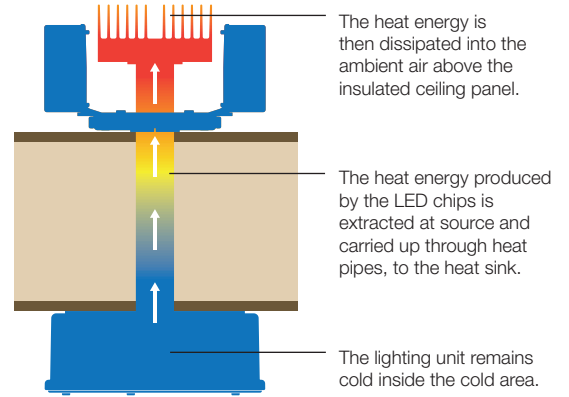
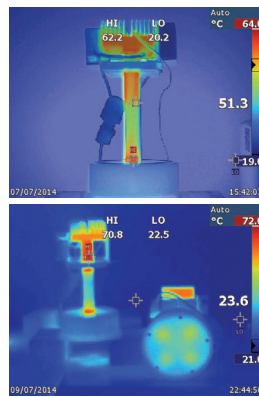

Installation Options

Chil-LED™ can be fitted to varying thicknesses of insulated envelope chilled and frozen environments, up to a ceiling panel depth of 200mm.

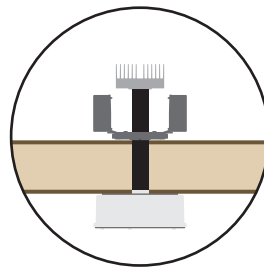

Flush Fitting- thin ceiling insulation- low profile.

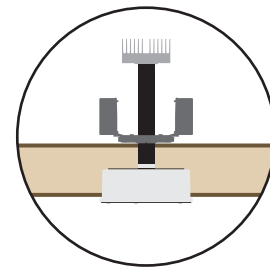

Recessed Fitting- thin ceiling insulation- maximises use of space.

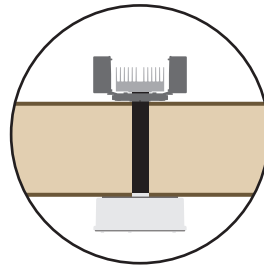

Flush Fitting- thick ceiling insulation- low profile.

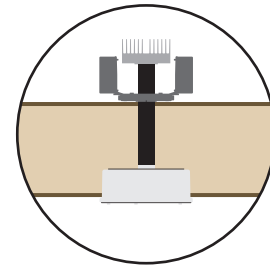

Recessed Fitting- thick ceiling insulation- maximises use of space.

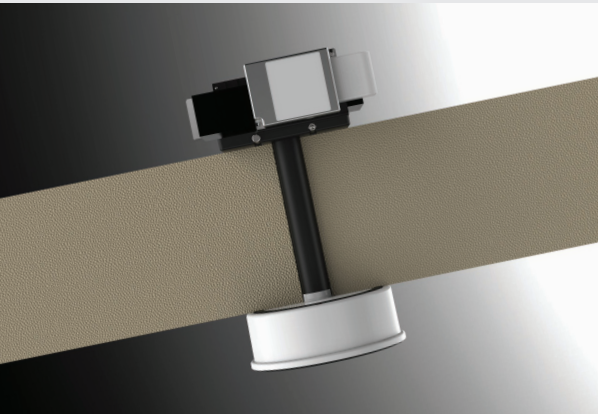



Reliability

- Sealed to IP65
- Top quality, long life, UK manufactured LED driver modules
- Latest generation LED chips and lenses
- Designed and assembled in the UK
- 5 Year Extended Warranty
- Save energy, save money

Chil-LED™ is an ultra-low profile design, reducing ceiling clutter, maximising usable space and avoiding the possibility of impact from fork lift trucks. In cases where ceiling clearance is very tight, Chil-LED™ can even be recessed into the insulated panel, creating a flush, level surface. **Olivewood Chil-LED™** is a unique, bespoke and innovative lighting system that offers a wide spectrum of features and benefits. It is unrivalled in its efficiency, performance, practicality, quality and reliability. Chil-LED™ provides maximum immediate and long term financial savings with excellent returns on investment.

Technical Specifications

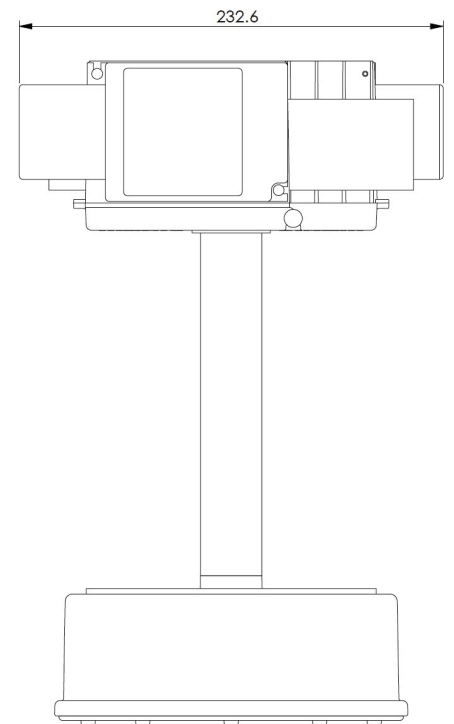
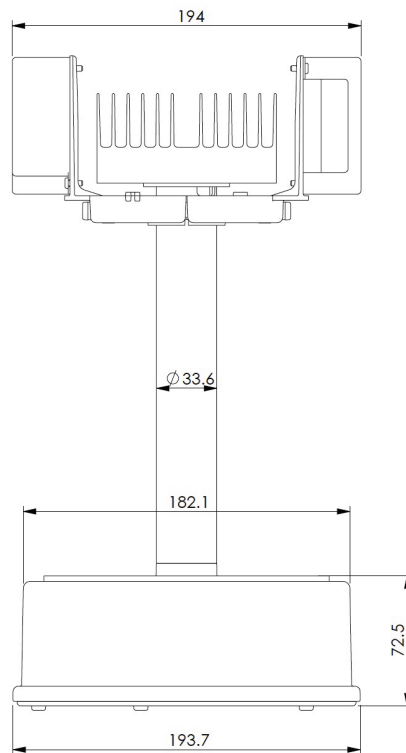

Product Version	Chil-LED™56 <small>The Coolest Light for Cold Places</small>	Chil-LED™80 <small>The Coolest Light for Cold Places</small>
LED Power	56 Watts	80 Watts
System Power	63 Watts	87 Watts
Voltage Range	220-240Vac rms nominal	220-240Vac rms nominal
Power Factor	95	95
Drive Current	350mA	500mA
LED Efficacy	120Lm/W	115Lm/W
LED Initial Output	6720Lm	9200Lm
Maintained Lumens	6600Lm	8400Lm
CCT	5000	5000
CRI	80	80
Beam Angle	26° / 50° / 80°	26° / 50° / 80°
Weight	3.10KG	3.15KG
Driver Type	Harvard Engineering CLQ2700S-240-C	Harvard Engineering CLQ21000S-240-C
Driver Qty	1	2
Driver Efficiency	89%	89%
Heat Pipe Capacity	60 Watts	60 Watts
Mounting Cutout Dia	34mm	34mm
Max Insulation Thickness	200mm	200mm
Min Insulation Thickness	50mm	50mm

For further energy saving information and services see our website: <http://olivewoodtech.co.uk>

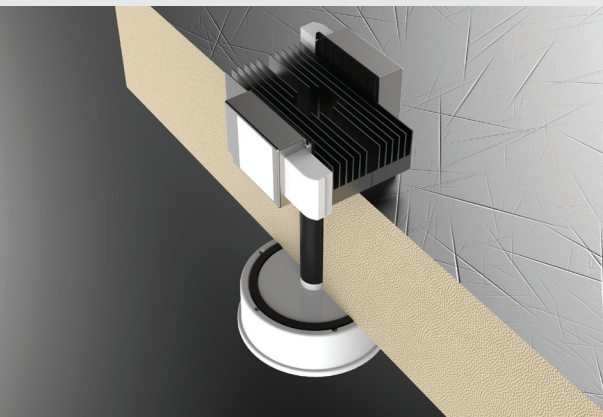

Patent Application
No. 1407673.1

